

Jector Punches For Heavy Load With Locating Dowel Holes(Finished For Retainers)
 厚板用附定位孔頂料沖頭(已做配合沖頭固定座加工)

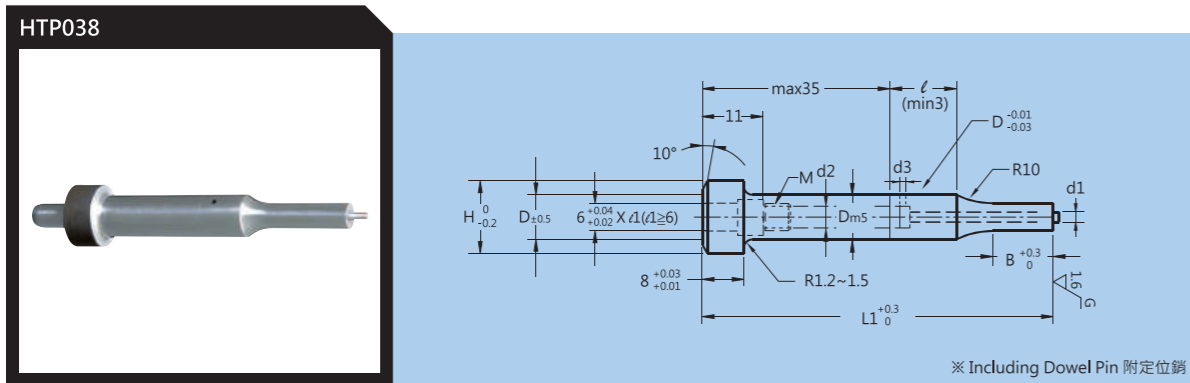

※ Including Dowel Pin 附定位銷

Type 品名	Material 材質	Hardness 硬度	Delivery 交貨日
HTP038	SKH51	61~64HRC	8 Working Days 8 個工作日

D Tolerance 柄部直徑公差
m5

Type of Tip Shape 刃口形狀	I	II	III	IV	V
		$R=0$ Can be Selected 可指定 $R=0$ $P \geq W$ $K = \sqrt{P^2 + W^2}$	$P \geq W$ $0.15 \leq R < \frac{W}{2}$ $K = \sqrt{(P-2R)^2 + (W-2R)^2} + 2R$	$P > W$	$P > W$

Type 品名	Tip Length 刃口長度	D	L1 (u: 10mm)	I (u:0.01mm) min. P max.	II/III/IV/V (u:0.01mm) P·Kmax.	II/III/IV/V (u:0.01mm) P·Wmin.	III (u:0.01mm) R	B	H	d1	d2	d3	M
HTP038	S	10	(60)~(130)	5.00~9.99	9.97	5.00	$0.15 \leq R < \frac{W}{2}$	13	15	1.8	4.4	1.5	5
		13	(60)~(130)	6.00~12.99	12.97	6.00		13	18	2.8			
		16	(60)~(130)	10.00~15.99	15.97	6.00		19	21				
		20	(60)~(130)	13.00~19.99	19.97	6.00		19	25				
		25	(60)~(130)	18.00~24.99	24.97	6.00		19	30				
	L	10	(60)~(130)	5.00~9.99	9.97	5.00		19	15				
		13	(60)~(130)	6.00~12.99	12.97	6.00		19	18	2.8			
		16	70~(130)	10.00~15.99	15.97	6.00		25	21				
		20	70~(130)	13.00~19.99	19.97	6.00		25	25				
		25	70~(130)	18.00~24.99	24.97	6.00		25	30				

* L1 (60)→B=8 If full length is (60), tip length is 8mm in all cases. 全長為(60)時·刃口長度一律為8mm

* I: P>D-0.03→ $\epsilon=0$ If P>D-0.03 for a round punch, D_{-0.03}^{-0.01} (press-in lead) is not included. 圓沖頭P>D-0.03時·不附D_{-0.03}^{-0.01}(導入部)

* II/III/IV/V: P·K>D-0.05→ $\epsilon=0$ If P·K>D-0.05 for a shaped punch, D_{-0.03}^{-0.01} (press-in lead) is not included. 變形沖頭P·K>D-0.05時·不附D_{-0.03}^{-0.01}(導入部)

Jector Punches For Heavy Load With Locating Dowel Holes(Finished For Retainers)
 厚板用附定位孔頂料沖頭(已做配合沖頭固定座加工)

Order Ex. 訂購範例

HTP038-10-L1-P-W-□-□

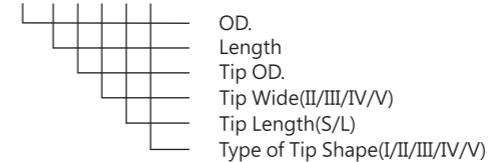

外徑
長度
前端外徑
前端寬度(II/III/IV/V)
刃口長度(S/L)
刃口形狀(I/II/III/IV/V)

Alterations	追加加工名稱	Description	加工說明	Alterations	追加加工名稱	Description	加工說明	
Alterations to Tip 刃口追加加工	BC		Tip length change 變更刃口長度 *請參考表13	Alterations to Full Length 全長追加加工	LKC		Full length tolerance change 變更全長公差	
	SC		Lapping of tip 刃口拋光加工		Alterations to Head 頭部追加加工	KC WKC KFC NKC		Addition key flats 止迴追加加工
	PRC		Rounding of tip side edge 刃口側端面R加工	Alterations to Shank 柄部追加加工		AC		The jector pin is removed to create an air path and the side vent hole is plugged from the inside by inserting a resin (ABS) ring. 作為空壓用·將頂出銷拔除·放入環狀樹脂(ABS)從內側將橫孔塞柱
	PCC		Chamfering to tip side edge 刃口側端面C倒角加工			NC		The jector pin is removed. 拔除頂出銷
	PKC		Tip tolerance change 變更刃口公差		TPC		Dowel pin change 變更定位銷	
Alterations to Full Length 全長追加加工	LC		Full length change 變更全長 *請參考表6	NDC		No press-in lead 無導入部		

*追加加工詳細說明請參考產品概要-追加加工說明