

HTP042

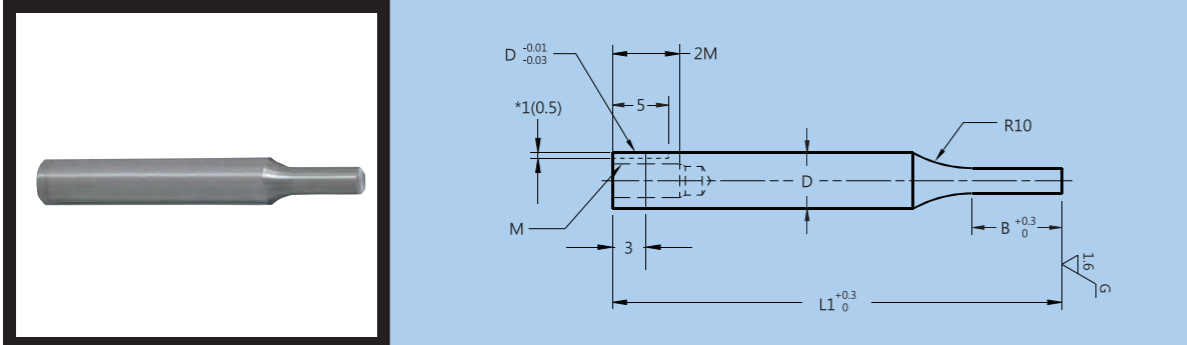

Type 品名	Material 材質	Hardness 硬度	Delivery 交貨日
HTP042-A	Equivalent to SKD11 SKD11同級	60~63HRC	8 Working Days 8 個工作日
HTP042-B			
HTP042-C	Powdered Highspeed Steel 粉末高速鋼	64~67HRC	

D Tolerance 柄部直徑公差	
a	m5
b	+0.005 0

HTP042-B只適用a公差
HTP042-B only used for a

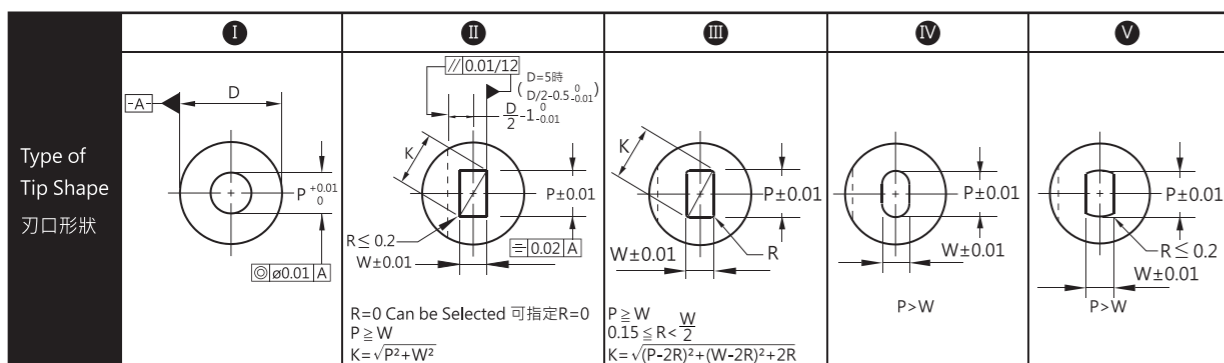

Type 品名	Tip Length 刃口長度	D	L1 (u: 10mm)	I (u:0.01mm) min. P max.	II/III/IV/V (u:0.01mm) P·Kmax.	II/III/IV/V (u:0.01mm) P·Wmin.	III (u:0.01mm) R	B	M
HTP042-A HTP042-C	S	5	40~80	2.00~4.99	4.97	1.20	$0.15 \leq R < \frac{W}{2}$	8	3
		6	40~80	2.00~5.99	5.97	1.50		8	3
		8	(40)~100	3.00~7.99	7.97	2.00		13	4
		10	(40)~100	3.00~9.99	9.97	2.50		13	5
		13	(40)~100	6.00~12.99	12.97	3.00		13	6
		16	(40)~100	10.00~15.99	15.97	4.00		19	6
		20	(40)~100	13.00~19.99	19.97	5.00		19	6
	25	(40)~100	18.00~24.99	24.97	6.00	19		6	
	L	5	50~80	2.00~4.99	4.97	2.00		13	3
		6	50~80	2.00~5.99	5.97	2.00		13	3
		8	50~100	3.00~7.99	7.97	2.50		19	4
		10	50~100	3.00~9.99	9.97	2.50		19	5
		13	50~100	6.00~12.99	12.97	3.00		19	6
		16	60~100	10.00~15.99	15.97	4.00		25	6
20		60~100	13.00~19.99	19.97	5.00	25	6		
25	60~100	18.00~24.99	24.97	6.00	25	6			

Further dimensions on request
規格尺寸若另有需求·歡迎洽詢

※ u=unit

Type 品名	Tip Length 刃口長度	D	L1 (u: 10mm)	I (u:0.01mm) min. P max.	II/III/IV/V (u:0.01mm) P·Kmax.	II/III/IV/V (u:0.01mm) P·Wmin.	III (u:0.01mm) R	B	M
HTP042-A HTP042-C	X Tip Length 刃口長度 X>L>S	5	60~80	2.00~4.99	4.97	3.50	$0.15 \leq R < \frac{W}{2}$	25	3
		6	60~80	2.00~5.99	5.97	3.50		25	3
		8	60~100	3.00~7.99	7.97	5.00		30	4
		10	60~100	3.00~9.99	9.97	5.00		30	5
		13	60~100	6.00~12.99	12.97	5.00		30	6
		16	70~100	10.00~15.99	-	-		40	6
		20	70~100	13.00~19.99	-	-		40	6
		25	70~100	18.00~24.99	-	-		40	6

Type 品名	Tip Length 刃口長度	D	L1 (u: 10mm)	I (u:0.01mm) min. P max.	II/III/IV/V (u:0.01mm) P·Kmax.	II/III/IV/V (u:0.01mm) P·Wmin.	III (u:0.01mm) R	B	M
HTP042-B	S	16	(40)~100	10.00~15.99	15.97	4.00	$0.15 \leq R < \frac{W}{2}$	19	8
		20	(40)~100	13.00~19.99	19.97	5.00		19	8
		25	(40)~100	18.00~24.99	24.97	6.00		19	8
	L	16	60~100	10.00~15.99	15.97	4.00		25	8
		20	60~100	13.00~19.99	19.97	5.00		25	8
		25	60~100	18.00~24.99	24.97	6.00		25	8

* L1 (40) : B=8 If full length is (40), tip length is 8mm in all cases. 全長為(40)時·刃口長度一律為8mm

Order Ex. 訂購範例

HTP042-□-5-L1-P-W-□-□-□

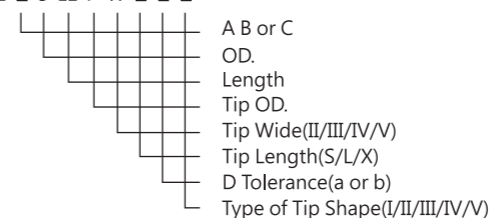

沖頭材質
 外徑
 長度
 前端外徑
 前端寬度(II/III/IV/V)
 刃口長度(S/L/X)
 柄部直徑公差(a or b)
 刃口形狀(I/II/III/IV/V)

Alterations	追加加工名稱	Description	加工說明	Alterations	追加加工名稱	Description	加工說明
Alterations to Tip 刃口追加加工	PC WC	Tip dimension change 變更刃口尺寸 *請參考表11		Alterations to Full Length 全長追加加工	PKC	Tip tolerance change 變更刃口公差	
	BC	Tip length change 變更刃口長度 *請參考表10			LC	Full length change 變更全長 *請參考表1	
	SC	Lapping of tip 刃口拋光加工		Others 其他	LKC LKZ	Full length tolerance change 變更全長公差	
	PRC	Rounding of tip side edge 刃口側端面R加工			KC WKC NKC	Addition key flats 止迴加工	
	PCC	Chamfering to tip side edge 刃口側端面C倒角加工		SKC	Single key flat on shank 柄部平面加工(1面)		
	GC	Tapper machining of the pin tip 錐度加工 *請參考表1		*追加加工詳細說明請參考產品概要-追加加工說明			