

SZ-SOPF

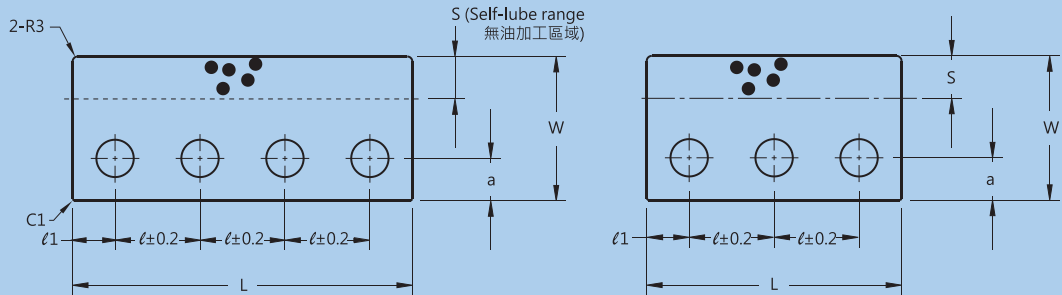
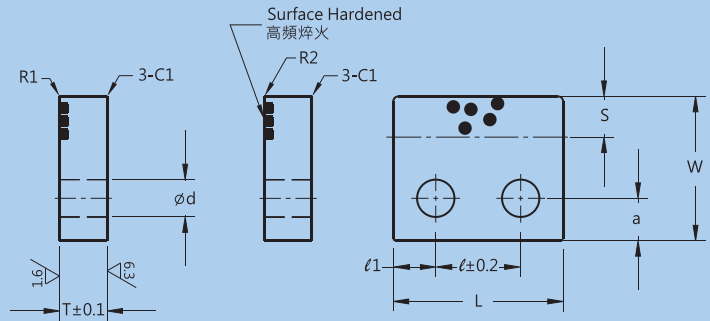
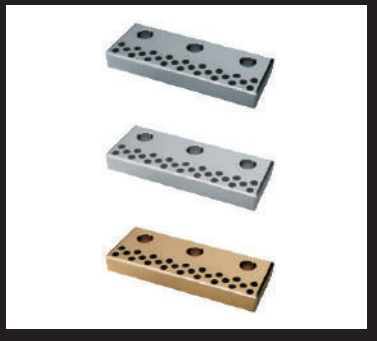

Type 品名	Material 材質	Heat Treatment 熱處理	Hardness 硬度	Delivery 交貨日
SZ-SOPF-A	FC250+Graphite FC250+石墨	-	-	10 Working Days 10 個工作日
SZ-SOPF-B	S45C+Graphite S45C+石墨	Surface Hardened 高頻淬火	40HRC ~	
SZ-SOPF-C	Brass+Graphite 高力黃銅+石墨	-	-	

Type	W	L	ℓ	$\ell 1$	a	s	d	T	Bolts
SZ-SOPF-A SZ-SOPF-B SZ-SOPF-C	55	180	120	30	17.5	24	18	25	2
		160	110	25	20	30			2
		200	75						3
		240	90	30					3
	70	200	75	25			25	30	22
		240	90	30	3				
		300	80	40	4				
		350	90		4				
	100	200	75	25	30	30	22	28	3
		240	90	30					3
		300	80						4
		350	90	40					4

Order Ex. 訂購範例

SZ-SOPF-A-W-L